

dv/dt MOTOR PROTECTION
OUTPUT FILTER

V1k



Limits voltage spikes below 1,000 Volts for long lead applications

- Greatly extends the life of the motor and cable
- Specific applications can reach 3,000 feet
- 30% reduction in Common Mode Current



dv/dt MOTOR PROTECTION OUTPUT FILTER

V1k

Voltage Without V1k

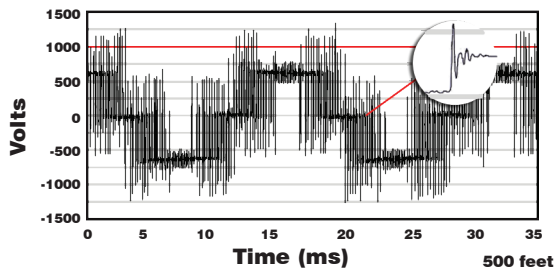

Voltage With V1k

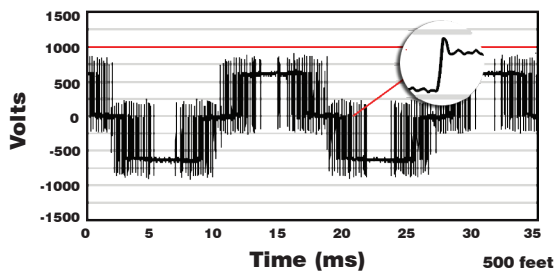

Common Mode Without V1k

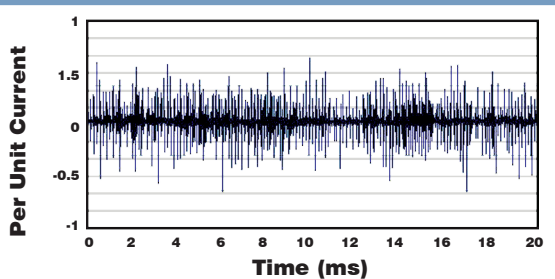

Common Mode With V1k

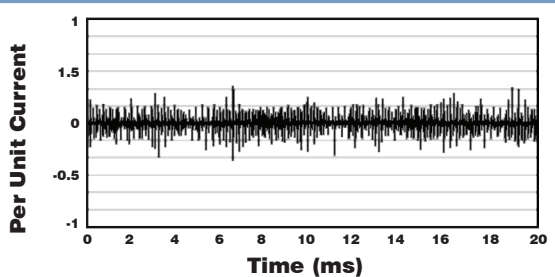

Typical Problems, Superior Solutions with V1k

As Pulse Width Modulated (PWM) Drives are incorporated into various applications and processes, the increased energy savings and decreased maintenance on Drives can be offset by increases in Motor failures.

The KLC-Series V1k product family has been designed as an engineered solution for motor failures due to the reflected wave phenomenon.

Reflective Wave Phenomenon

Voltage wave reflection is a function of the voltage rise time (dv/dt) and the length of the motor cables.

The impedance on either end of the cable run does not match, causing voltage pulses to be reflected back in the direction from which it arrived. As these reflected waves encounter other waves, their values add, causing higher peak voltage.

As wire length or carrier frequency increases, the overshoot peak voltage also increases.

Peak Voltages on a 460V system can reach 1200 to 1600V, causing rapid breakdown of motor insulation, leading to motor failure. On 575V systems, the peak voltages can easily reach 2100V. If this is left uncontrolled, insulation failure may occur.

Mitigate Reflective Wave

By combining a patented dampening circuit with a low pass filter, V1k filters:

- Increase the voltage rise time (dt out of dv/dt)
- Prevent voltage spikes from exceeding 1,000 V
- Slow pulse transitions, reduce dv/dt by a factor of 3 or more
- Protect motor and cable insulation

Reduces Common Mode Motor and Bearing Currents

Common Mode current, which lead to shaft voltages, bearing pitting, and bearing fluting is reduced by a minimum of 30%. V1k filters:

- Slow down the pulse dv/dt by a factor of 3, reducing the harmful common mode currents
- Increase bearing life and up-time
- Reduce common mode noise and currents

The V1K prevents voltage spikes from exceeding 1,000 V up to 2,000 feet and limits dv/dt to less than 1,000 V/ μ s. The product has been used successfully in applications up to 3,000 feet depending on cable and VFD sizes.

Part Numbering System

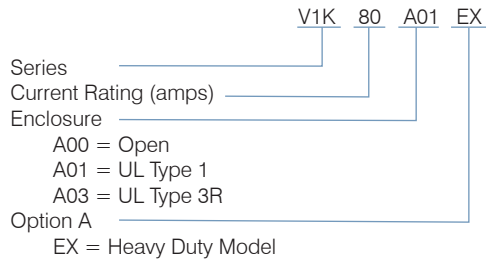

One Line Diagram of Patented Design

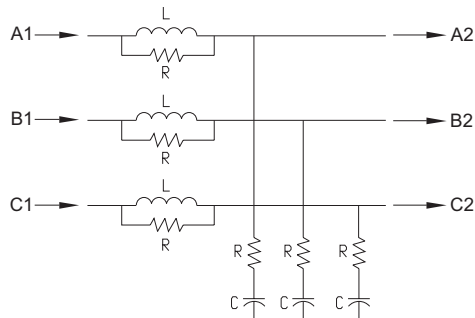

Multiple Motor Applications

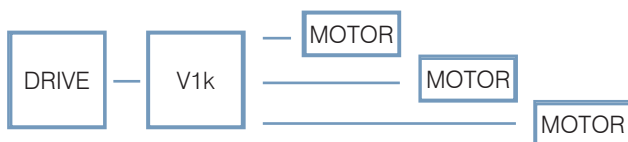

Please see web site for configuration guidelines.

Product Specifications

- Ratings: 2 - 750 amps; 240 V - 600 V; 7.5 - 600 HP
- Carrier Frequency: 1 - 12 kHz
- Fundamental Frequency: 0 - 60 Hz (consult factory for applications over 8 kHz and/or 60 - 120 Hz fundamental if the cable lengths exceed 400 feet)
- Efficiency: > 98%
- Insulation Rating: 600V Class
- Insulation Class:
Class H (180°C) or Class R (220°C)
- Ambient Temperature: 40° C
- Maximum Altitude: 2,000 meters (6,000 feet)
Derating necessary above 2,000 meters
- Agency Approvals: cUL, UL
- Enclosures: Open, UL Type 1, UL Type 3R
- Lead Length: Specific applications can reach 3,000 feet (consult factory for applications above 1,500 feet)
- Operation possible up to 120 Hz output drive frequency with derating (contact factory for details)

PERFORMANCE GUARANTEE

Properly sized and applied, TCI guarantees that the V1k will limit motor terminal peak input voltage to 150% of the bus voltage with a wire lead length of 1,000 feet and a carrier frequency of 4 kHz. Maximum lead length and carrier frequency can vary depending on wire lead type.

If a properly selected, installed and loaded V1k filter fails to meet the guaranteed performance levels, TCI will provide the necessary components or replacement filter at no additional charge.

TCI does not take responsibility for additional installation or removal costs to include but not limited to replacement of third party equipment. Please see TCI web site for minimum system requirements.



Reliable  Advanced Power Quality

V1k Typical Applications:

- Oil and Gas Pumps
- Irrigation Fields, Farms
- Water, Wastewater
- HVAC
- Pulp, Paper

Additional Power Quality Solutions:



KDR Line Reactor

- Prevents nuisance tripping
- Protects the source by lowering current distortion created by the drive



HG7 Passive Harmonic Filter

- Helps meet IEEE-519
- Reduces harmonic distortion to less than 7% TDD at full load
- Improves power factor



H5 Active Harmonic Filter

- Helps meet IEEE-519
- Reduces harmonic distortion to less than 5% TDD at full load
- Actively monitors the load current while returning the power factor to near unity
- Built-in touchscreen display & Modbus RTU



KRF EMC Filter

- Filter EMI/RFI noise caused by power switching devices
- Meet FCC regulation 15, subpart 3
- Prevents interference with automated lighting circuits, security cameras, and other critical electronics



KMG Motor Protection Output Filter

- Protects the motor by converting the PWM waveform into a near sinusoidal wave
- Prevents voltage overshoots that cause early degradation of insulation systems in motors, transformers, and cables
- Extends motor life by reducing operating temperature

Part Number: 25383 Version 1.5

© Copyright 2011

TCI, LLC
www.transcoil.com

7878 North 86th Street
Milwaukee, WI 53224
USA

Toll Free: 800-824-8282
P: 414-357-4480
F: 414-357-4484

Please contact us about
specific products and services.



Line Reactors • Harmonic Filters • EMC Filters • dv/dt Filters • Sinewave Filters