

# SHARK<sup>®</sup> 250

Power & Energy Meter for Utility and Critical Industrial Substations



## Revenue Metering

- ANSI C12.20 0.1 Accuracy Class
- Perpetual Time of Use, Transformer/Line Loss Compensation, and Test Mode
- Real Time SCADA Communication Capability: Modbus RTU, Modbus TCP/IP, Level 2 DNP3, and IEC 61850
- Multiple Communication Ports: USB Front Port, RS485 Port, and Two Optional Ethernet Ports
- 128 MB Memory for Logging and Data Storage
- Upgradable I/O
- Cyber Secured Configuration
- MV90 Support
- Rugged Design and Standard Conformal Coating

## Power Quality Metering

- PQ Analyzer with Limits, THD Monitoring, and Harmonics Recording
- 512 Samples/Cycle Waveform Recording on Surge and Sag Events
- Large Onboard Waveform Storage
- Millisecond Time Stamp for Accurate CBEMA and SEMI F47

## Applications

- Utility Substation Metering
- Industrial Control Panels
- Distribution Automation
- Power Quality Studies
- Alternative Energy
- SCADA Metering

## Introduction

The Shark® 250 meter is the latest addition to the Shark® Series power and energy meter line. Designed for Utility substation and critical industrial applications, its features include:

- Enhanced Revenue metering features, such as onboard Time of Use, CT/PT compensation, Test Mode and Energy presets, pulse accumulators and totalizers.
- Multiple serial or Ethernet ports for redundant communication.
- Front panel USB port.
- Large memory capacity for more significant load studies, including longer storage without overwriting of data.
- Cyber secured configuration for nonintrusive substation use.
- Rugged design for harsh environments, with standard conformal coating and superior surge withstand capability.
- Level 2 DNP3 and IEC 61850.

## Enhanced 0.1% Class Revenue Metering Features

Utilities today face many challenges when metering customers. Installed meters need to be highly accurate and verifiable. Due to reductions in labor force, modern meters need to be both reliable and designed for a long operation life. The Shark® 250 meter meets these requirements with advanced metering technology and superior engineering to improve reliability. The meter is an ANSI C12.20 0.1 Accuracy Class meter that also conforms to the IEC 62053-22 CL 0.2S standard for accuracy. The Shark® 250 meter is designed to provide precise and reliable measurements that are highly stable, and that maintain accuracy over a long period of time. The Shark® 250 meter provides a comprehensive revenue energy measurement capability, including:

- Energy Test Pulse.
- Test Mode and Energy presets.
- Perpetual Time of Use.
- CT/PT compensation.
- Pulse accumulators and totalizers.
- Up to 8 Pulse Outputs and 8 Pulse Inputs.

## Time of Use

The Shark® 250 meter uses a perpetual Time of Use (TOU) calendar that only needs to be set up once. The TOU implementation allows the user to set up multiple rates to meet most contractual obligations. It also allows the user to customize any energy parameter for TOU. The 16 available TOU registers can be configured not only for TOU built-in energy readings, but also for any stored data from pulses or totalizers.

- Perpetual TOU calendar – set up only once and use indefinitely.
- Up to four seasons – seasons can be customized.
- Up to 12 months per year – set independently from seasons.
- Flexible billing periods/rates/holidays/schedules setup.
- Perform TOU on up to 16 configurable datasets consisting of 38 channels of data, including all energy channels, pulse data, readings per quadrant and phase, and pulse aggregators.
- Cumulative and continuous cumulative demand are available.

## CT/PT Compensation

For stringent accuracy requirements, the meter can compensate for the inaccuracies of the instrument transformers. The Shark® 250 meter has built-in features that allow a utility provider to adjust the energy meter to compensate for these inaccuracies, using both amplitude and phase angle adjustments. CT reversal setting is supported.

## Loss Compensation

The meter can compensate energy readings for transformer and line losses. This allows a utility to properly bill a customer for usage, even if the meter is placed on the secondary side of the transformer.



# Cyber Secured Configuration

The Shark® 250 meter uses a multi-level Cyber Secure encrypted configuration to protect your metering data. The meter's Cyber security is designed to prevent tampering and hacking of your power system data. Features of the meter's unique Cyber Security include the following:

- Highly secure encrypted passwords.
- 9 user IDs and passwords - up to 30 characters in length to insure password strength.
  - An administrator and up to 8 user IDs can be created.
- Password fail timeouts to eliminate brute force attacks.
- Access to the following functions can be controlled:
  - Reset energy readings.
  - Upload firmware.
  - Reset demand.
  - Download and reset logs – access can be controlled for each log, independently.
  - Edit TOU calendar, read TOU data, and reset TOU accumulators.
  - Edit and upload programmable settings.
  - Execute Test Mode.
  - Edit CT/PT compensation.
  - Back up meter files.
  - Control read access for a COM port.
  - Access control functions for I/O.
  - Reset input and output counters.
  - Meter restart.
  - Manual waveform capture date/time.
  - Set preset energy.
  - Change V-Switch™ key.

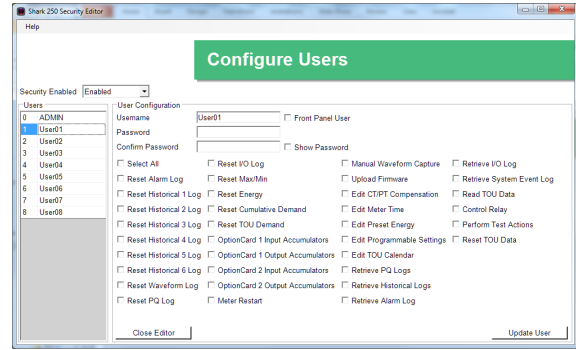

The meter's Cyber secured configuration is easily set up using EIG's CommunicatorPQA™ software.

# Robust Communication for Utilities

The Shark® 250 meter is equipped with an advanced communication architecture suited to the specific needs of Utilities. The Shark® 250 meter allows up to 4 serial and Ethernet communication ports, including a front panel USB, a standard RS485, optional RS232/RS485, and up to two Ethernet ports.

- Level 2 DNP3 (available for 1 serial and/or 1 Ethernet port) and/or IEC 61850.
- Modbus RTU/ASCII/TCP.
- NTP, SMTP, HTTP Ethernet protocols.
- Ethernet ports and Serial ports.

# Standard Communication

## USB Port

- For laptop PC read and programming.
- Modbus ASCII, 57.6k baud.

## RS485 Port

- Level 2 DNP3.
- Modbus RTU/ASCII, up to 57.6k baud.

USB Mini-B Connection →

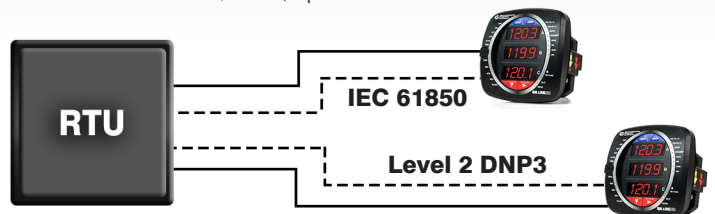

# Field-Expandable I/O and Communication Capabilities

**The Shark® 250 meter offers unequaled I/O expandability.** Using the two universal option slots, the unit can be easily configured to accept new I/O cards even after installation. The unit auto-detects installed I/O option cards. Up to 2 cards of any type can be used per meter. For metering applications, it is imperative to not only measure the energy data, but also to be able to communicate this real time data, in order to meet many operational needs. The Shark® 250 meter is able to send data to many different systems, using multiple open protocols. These protocols include Modbus RTU/ASCII/TCP, Level 2 DNP3 and IEC 61850. The meter's communication architecture is flexible, and designed to integrate directly into most existing systems.

## INP100S: 100BaseT Ethernet Capability

- NTP time server for high accuracy network time synchronization.
- 12 simultaneous Modbus TCP/IP connections.
- 5 simultaneous Level 2 DNP3 over Ethernet connections.



## INP300S: IEC 61850 Protocol Ethernet Card

- Simultaneous communication of IEC 61850 and Modbus TCP/IP.
- 5 simultaneous MMS clients.
- Multiple logical nodes.



## 1mAOS: Four Channel Bi-directional 0-1 mA Outputs

- Assignable to any parameter.
- 0.1% of full scale.
- Max. Load Impedance 10 kΩ.



## 20mAOS: Four Channel 4-20 mA Outputs

- Assignable to any parameter.
- 0.1% of full scale.
- 850 Ω at 24 V DC.
- Loop powered using up to 24 V DC.



## PO1S: Four Pulse Outputs / Four Status Inputs

- Programmable to any energy parameter and pulse value.
- Form A: Normally open contacts.
- Also used for End of Interval pulse.



## RO1S: Two Relay Outputs / Two Status Inputs

- 250 V AC / 30 V DC - 0.25 A relays, form C.
- Trigger on user set alarms.
- Set delays and reset delays.



## FOVPS or FOSTS: Fiber Optic Card

- EIG's exclusive Fiber Optic Daisy Chain switchable built-in logic mimics RS485 half duplex bus, so you can daisy chain meters for lower installation costs. Full duplex is also assignable.
- ST Terminated Option (-FOSTS).
- Versatile Link Terminated Option (-FOVPS).
- Modbus and Level 2 DNP3 protocols available.



## RS1S: Serial Communication Card

- Programmable RS485 or RS232 Port.
- Up to 2 ports per meter in addition to the standard RS485 port.
- One session at a time of DNP3 serial communication is available per meter.

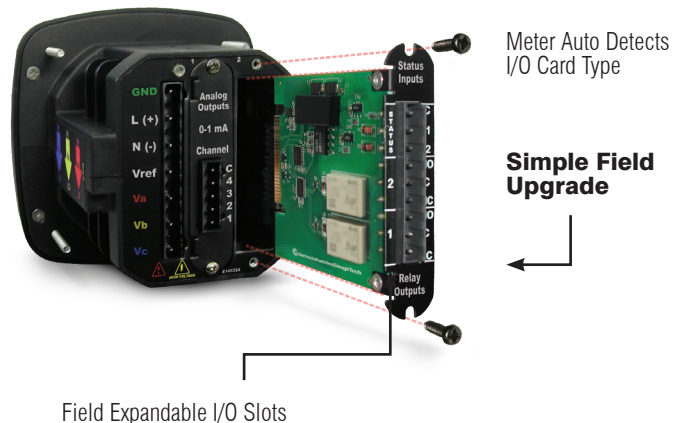

# Large Memory Capacity

The Shark® 250 meter offers up to 128 MB memory for logging and data storage. This large memory capacity facilitates:

- More significant load studies.
- Longer storage without overwriting of data.
- Flash sector profiling for improved long-term operation.

| Feature                           | V-Switch™ Key 3   | V-Switch™ Key 4  |
|-----------------------------------|---|--|
| <b>Storage and Logging Memory</b> | 10 MB   | 128 MB   |
| <b>Logging Capability</b>         | 36 months of recording and storage for 4 energy values recorded every 15 minutes; up to 79 waveform record captures | 76 months of recording and storage for 4 energy values recorded every 15 minutes; up to 319 waveform record captures |
| <b>Waveform Recording</b>         | Up to 128 samples per cycle   | Up to 512 samples per cycle  |

## Historical Logs

- Up to 6 assignable historical logs.
- Independently programmed trending profiles.
- Up to 64 parameters per log.

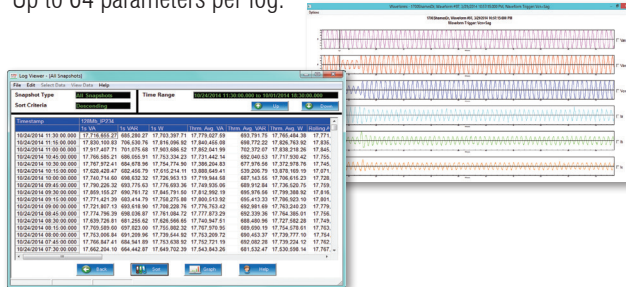

## System Events Log

To protect critical billing information, the meter records and logs the following with a time stamp:

- Demand resets.
- System startup.
- Energy resets.
- Log resets.
- Critical data repairs.
- Programmable settings changes.
- Password requests/sealing switch changes.

## I/O Change Log

- Provides a time stamped log of any relay output.
- Provides a time stamped log of input status changes.
- 2048 events available.

## Limit/Alarm Log

- Provides magnitude and duration of an event.
- Includes time stamps and alarm value.
- 2048 events available.
- Email on alarm capability with INP100S Ethernet card.

## Limit Alarms and Control Capability

Limit Events:

- Any measured parameter.
- Up to 16 limits.
- Voltage unbalance.
- Current unbalance.
- Based on % of full scale settings.

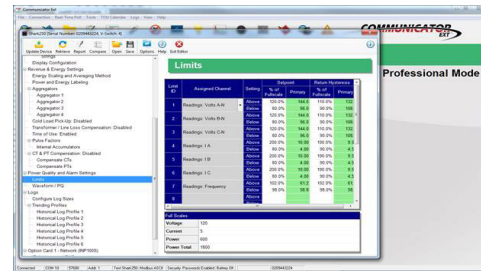

Limits Alarms Screen

## Rugged Design

The Shark® 250 meter is designed for harsh environments. It features:

- Standard PCB conformal coating on all circuit boards.
- Compliant to IEC 610186-1/2/3 (high reliability).
- Improved surge withstand capability.
- Intrinsically safe current connections.

# Power Quality Measurement and Analysis

The Shark® 250 meter records up to 512 samples per cycle for a voltage sag or swell, or a current fault event. The unit provides the pre and post-event recording capability shown in the table below. Waveform records are programmable to the desired sampling rate. V4 provides up to 128 MB of storage.

The meter's advanced DSP design allows power quality triggers to be based on a 1 cycle updated RMS. Hundreds of events can be stored until the memory fills. The meter stores waveform data in a first-in/first-out circular buffer to insure data is always recording.

## Optional Waveform Recorder

|           | Samples per Cycle | Pre Event Cycles | Post Event Cycles | Max Waveform per Event |
|-----------|-------------------|------------------|-------------------|------------------------|
| <b>V3</b> | 32                | 16               | 48                | 128                    |
|           | 64                | 8                | 24                | 64                     |
|           | 128               | 4                | 12                | 32                     |
| <b>V4</b> | 256               | 2                | 6                 | 16                     |
|           | 512               | 1                | 3                 | 8                      |

**Note:** Sampling rate based on 60 Hz systems. For 50 Hz systems, multiply by 1.2.

## Waveform Scope

The unit uniquely offers a waveform scope to view the real time waveform for voltage and current. The waveform scope allows the meter to be used as a basic oscilloscope throughout a power system.

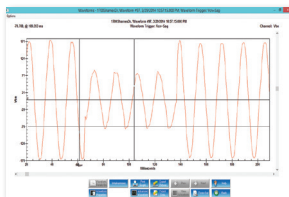

## Independent CBEMA (or SEMI F47) Log Plotting

The meter stores an independent CBEMA or SEMI F47 log for magnitude and duration of voltage events. This allows a user to quickly view total surges, total sags and duration, without retrieving waveform data. The meter also fully supports MV90. Time stamps are stored with millisecond accuracy.

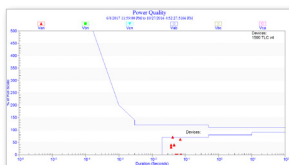

## Harmonic Recording to the 40th Order

The Shark® 250 meter provides advanced harmonic analysis to the 40th order for each voltage and current channel, in real time. Using the stored waveforms, harmonic analysis is available to the 255th order.



# V-Switch™ Key Technology

The Shark® 250 meter is equipped with V-Switch™ key technology, a virtual firmware-based switch that lets you enable meter features through software communication. V-Switch™ key technology allows meter up-grades after installation without removal from service.

| Features                            | V1 | V2 | V3 | V4 |
|-------------------------------------|----|----|----|----|
| <b>Basic Measurements</b>           |    |    |    |    |
| Multifunction Measurement           | ✓  | ✓  | ✓  | ✓  |
| Programmable Display                | ✓  | ✓  | ✓  | ✓  |
| Time of Use                         | ✓  | ✓  | ✓  | ✓  |
| System Events                       |    | ✓  | ✓  | ✓  |
| Input Status Change                 | ✓  | ✓  | ✓  | ✓  |
| Limits                              | ✓  | ✓  | ✓  | ✓  |
| Harmonics                           | ✓  | ✓  | ✓  | ✓  |
| 2 MB Memory * (3 Historical logs)   |    | ✓  |    |    |
| 10 MB Memory * (6 Historical logs)  |    |    | ✓  |    |
| 128 MB Memory * (6 Historical logs) |    |    |    | ✓  |
| Waveform 128 samples                |    |    | ✓  |    |
| Waveform 512 samples                |    |    |    | ✓  |
| CT/PT Comp                          | ✓  | ✓  | ✓  | ✓  |
| TLC Compensation                    | ✓  | ✓  | ✓  | ✓  |
| IEC 61850 Protocol **               |    | ✓  | ✓  | ✓  |
| Level 2 DNP3                        | ✓  | ✓  | ✓  | ✓  |
| Modbus Protocol ***                 | ✓  | ✓  | ✓  | ✓  |

\* Note that some memory is reserved for internal operations.

\*\* INP300S option card required.

\*\*\* See the Shark® 250 Meter Modbus Protocol Application Guide for instructions on using Modbus with the meter.

# Shark® 250T Transducer Mounting

This transducer version of the Shark® 250 meter does not include a display. The unit mounts directly to a DIN rail and provides an RS485 Modbus or DNP3 output and the expandable I/O.

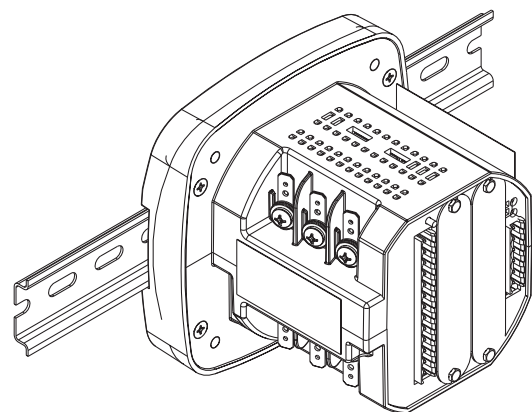

Easy DIN Rail Mounting

# Dimensional Drawings

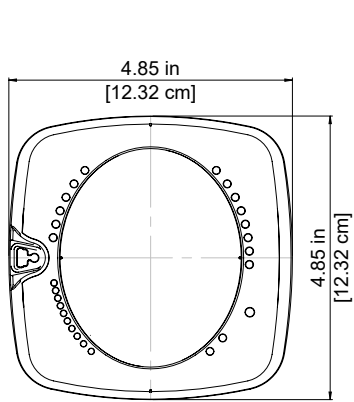

**Shark® 250 Meter  
Front Dimensions**

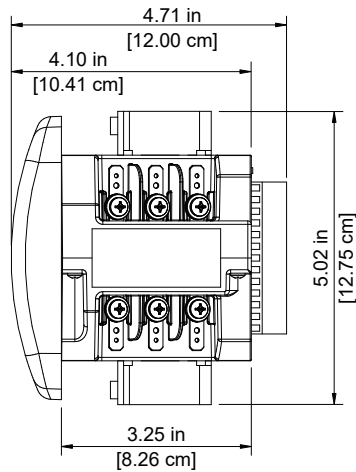

**Shark® 250 Meter  
Side Dimensions**

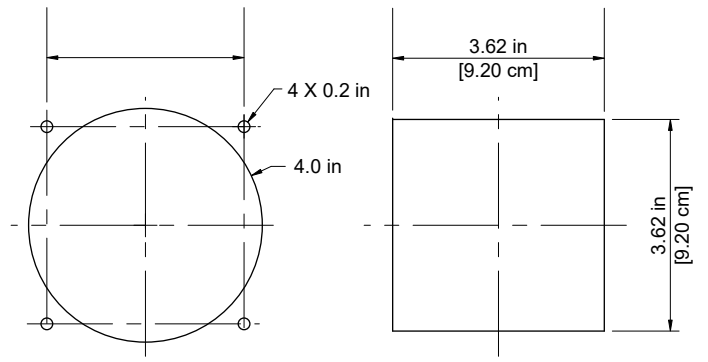

The unit mounts directly into an ANSI C39.1 or an IEC 92 mm DIN square form, perfect for new and existing installations.

**ANSI Mounting  
Dimensions**

**DIN Mounting  
Dimensions**

# Wiring Diagrams

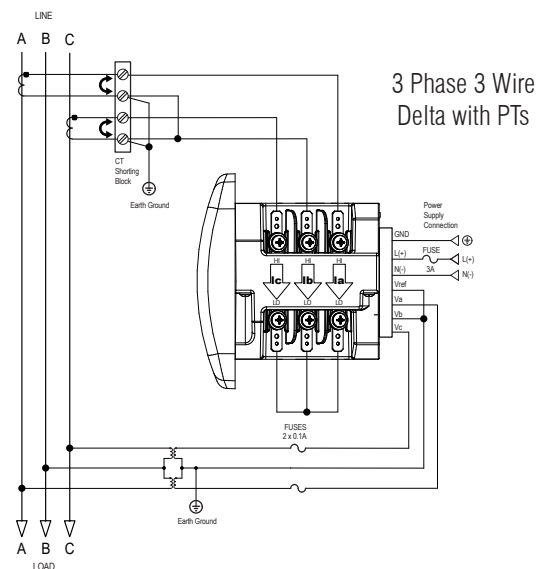
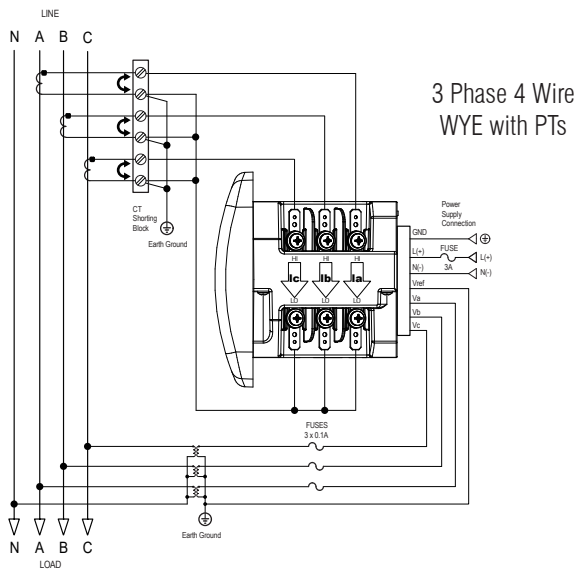
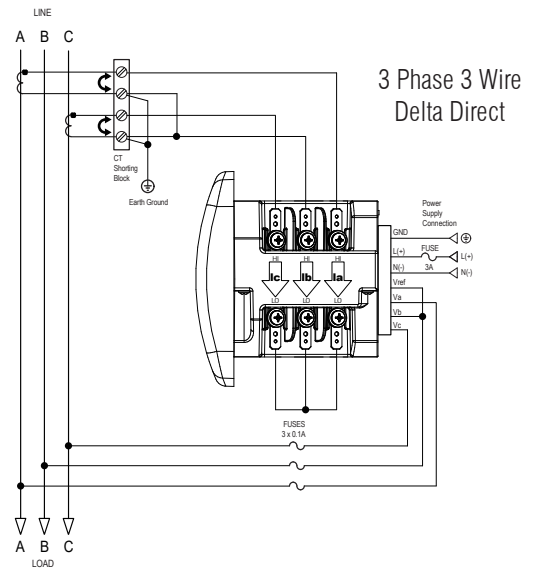
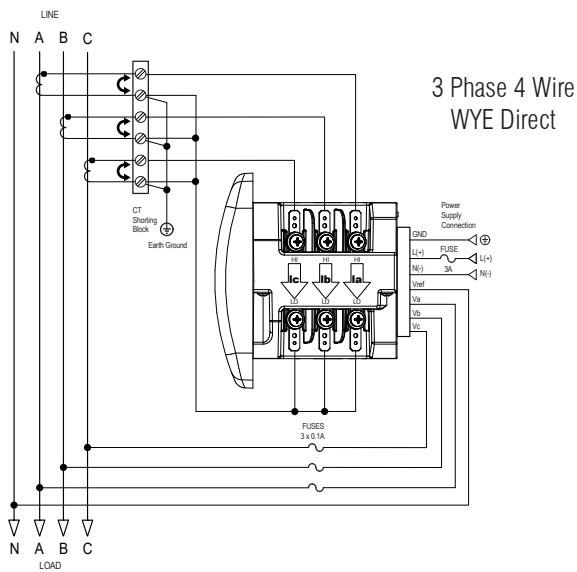

# Specifications

## Voltage Inputs:

- (20-576) Volts Line To Neutral, (0-721) Volts Line to Line
- Universal Voltage Input
- Input Withstand Capability – Meets IEEE C37.90.1 (Surge Withstand Capability)
- Programmable Voltage Range to Any PT Ratio
- Supports: 3 Element WYE, 2.5 Element WYE, 2 Element Delta, 4 Wire Delta Systems
- Burden: Input Impedance 8Ω; Burden 0.018 W at 120 Volts
- Input Wire Gauge: AWG#12 -26/(0.129 - 3.31) mm<sup>2</sup>

## Current Inputs:

- Class 10: (0.005 to 11) A, 5 A Nominal, 18 A max
- Class 2: (0.001 to 2) A, 1 A Nominal Secondary, 2 A Max
- Fault Current Withstand (at 23°C): 100 A for 10 Seconds, 300 A for 3 Seconds, 500 A for 1 Second
- Continuous Current Withstand: 20 A for Screw Terminated or Pass Through Connections

- Programmable Current to Any CT Ratio
- Burden 0.005 VA per Phase Max at 11 A
- Pickup Current: 0.1% of Nominal; Class 10: 5 mA, Class 2: 1 mA
- Pass Through Wire Diameter: 0.177"/4.6 mm

## Isolation:

- All Inputs and Outputs are Galvanically Isolated to 2500 Volts

## Environmental Rating:

- Storage: (-20 to +70) °C
- Operating: (-20 to +70) °C
- Humidity: to 95% RH Non-Condensing

## Faceplate Rating: NEMA 1

- Mounting Gasket Included
- Standard Conformal Coating
- Protection: IP30 - Meter Front/Back, Optional DIN Rail Mounting, Optional Plug-in I/O Modules

## Sensing Method:

- True RMS
- Sampling at over 400 Samples/Cycle on all Channels of Measured Readings Simultaneously

- Harmonics Resolution to 40th Order

- Waveform up to 512 Samples/Cycle

## Update Rate:

- Watts, VAR and VA - Every 6 Cycles
- All Other Parameters - Every 60 Cycles

## Power Supply:

- Option D2: Universal, (90 to 265) Volts AC or (100 to 370) Volts DC
- Option D1: (18-60) Volts DC (24 to 48 V DC Systems)
- Burden: 10 VA Max

## Standard Communication Format:

- 2 Com Ports (Back and Faceplate)
  - RS485 Port through Backplate
  - USB through Faceplate (uses USB Mini-B connector)
- Com Port Baud Rate: (1200 - 57600) bps
- Com Port Address: 1-247
- 8 Bit, Parity Setting: Odd, Even, None
- Modbus RTU, ASCII or Level 2 DNP3 Protocols

- IEC 61850 available with INP300S

## KYZ Pulse:

- Type Form C Contact
- On Resistance: 35 Ω Max
- Peak Voltage: 350 V DC
- Continuous Load Current: 120 mA
- Peak Load Current: 350 mA (10 ms)
- Off State Leakage Current @350 V DC: 1uA

## Dimensions and Shipping:

- Weight: 2 lbs /91 kg
- Basic Unit: H4.85" x W4.85" x L4.25"
- Shark® 250 Meter Mounts in 92 mm DIN or ANSI C39.1 4" Round Cutouts
- Shipping Container Dimensions: 6" Cube

## Meter Accuracy:

- 0.1% Energy Accuracy
- Note: For 2.5 element programmed units, degrade accuracy by an additional 0.5% of reading.
- Note: For 1A (Class 2) Nominal, degrade accuracy to 0.5% of reading for watts

## Compliance:

- ANSI C12.20 0.1 Accuracy Class
- ANSI (IEEE) C37.90.1 Surge Withstand
- ANSI C62.41 (Burst)
- IEC 61000-4-2 – Electromagnetic compatibility (EMC); Testing and measurement techniques; Electrostatic discharge immunity test
- IEC 61000-4-3 – Electromagnetic compatibility (EMC); Radiated, radio-frequency, electromagnetic field immunity test
- IEC 61000-4-4 – Electrical fast transient/burst immunity test
- IEC 61000-4-5 – Surge immunity test
- IEC 61000-4-6 – Immunity to conducted disturbances, induced by radio-frequency fields
- IEC 61000-4-7 – General guide on harmonics and interharmonic measurements and instrumentation
- IEC 61000-4-8 – Magnetic field immunity
- and energy; all other values 2 times rated accuracy.
- IEC 61000-4-11 – Voltage variations immunity
- EN 61000-6-2 – Immunity for Industrial Environments: 2005
- EN 61000-6-4 – Emission Standards for Industrial Environments: 2007
- EN 61326-1 – EMC Requirements: 2006
- IEC 61557-12 – Performance Measuring and Monitoring Devices (PMD)
- IEC 62053-22 (0.2S Accuracy)
- CISPR 11 – Radiated Emissions Class B
- Listed to UL/IEC 61010-1 3rd Ed. and CSAC22.2 No. 61010-1, UL File: E250818
- EU Directive 2011/65/EU (RoHS 2 Directive)
- REACH Compliant
- PCBs Conformal Coating: Complies with IEC 61086-1/2/3 (high reliability). For adverse environmental conditions.

## Ordering Information - All fields must be filled in to create a valid part number.

| Model                         | Frequency Range | Current Input    | V-Switch™ Pack   | Power Supply        | I/O Slot 1*  | I/O Slot 2*  | Mounting  |
|-------------------------------|-----------------|------------------|--|---------------------|--|--|---|
| <b>Option Numbers:</b>        | -               | -                | -  | -                   | -  | -  | -   |
| <b>Example:</b>               | <b>Shark250</b> | <b>60</b>        | <b>10</b>  | <b>V1</b>           | <b>D2</b>  | <b>INP100S</b>                                       | <b>X</b>  |
| <b>Shark250 (Meter)</b>       | 60 Hz System    | 10 Amp Secondary | V1 Measurement   | D2 (90-265) V AC/DC | X None   | X None   | X ANSI Mounting                                       |
| <b>Shark250T (Transducer)</b> | 50 Hz System    | 2 Amp Secondary  | V2 V1+2 MB Memory  | D (18-60) V DC      | RO1S 2 Relays/2 Status                               | RO1S 2 Relays/2 Status                               | DIN DIN Mounting Brackets (Not for transducer models) |
|                               |                 |                  | V3 V2+10 MB Memory and 128 Samples per Cycle Waveform Recording  |                     | PO1S 4 Pulses/4 Status                               | PO1S 4 Pulses/4 Status                               |   |
|                               |                 |                  | V4 V3+128 MB Memory and 512 Samples per Cycle Waveform Recording |                     | 1mAOS 4 Channel Analog Output 0-1 mA (bidirectional) | 1mAOS 4 Channel Analog Output 0-1 mA (bidirectional) |   |
|                               |                 |                  |  |                     | 20mAOS 4 Channel Analog Output 4-20 mA               | 20mAOS 4 Channel Analog Output 4-20 mA               |   |
|                               |                 |                  |  |                     | FOSTS Fiber Optic Output ST terminated               | FOSTS Fiber Optic Output ST terminated               |   |
|                               |                 |                  |  |                     | FOVPS Fiber Optic Output VPIN terminated             | FOVPS Fiber Optic Output VPIN terminated             |   |
|                               |                 |                  |  |                     | INP100S 100BaseT Ethernet                            | INP100S 100BaseT Ethernet                            |   |
|                               |                 |                  |  |                     | INP300S IEC 61850 Protocol Ethernet                  | INP300S IEC 61850 Protocol Ethernet                  |   |
|                               |                 |                  |  |                     | RS1S RS232/RS485 Comm Card                           | RS1S RS232/RS485 Comm Card                           |   |

## Accessories

- E205301** RS485 to USB Adapter
- CAB26522** USB-A to USB Mini-B Cable
- Unicom 2500** RS485 to RS232 Converter
- Unicom 2500-F** RS485 to RS232 to Fiber Optic Converter
- Certificate of Calibration, Part #: CCal** This provides Certificate of Calibration with NIST traceable Test Data.

## Software

- COMPQA5P1Y** CommunicatorPQA™ 5.0 Software for Windows Single-Computer License (One Year)

\*I/O cards can be ordered separately using the part numbers shown in the ordering information, with -KT added, e.g., INP100S-KT.



1800 Shames Drive, Westbury, NY 11590 **1-877-EIMETER**  
 (1-877-346-3837) **Tel:** 516-334-0870 **Fax:** 516-338-4741  
**Email:** sales@electroind.com **www.electroind.com**



**Shark® 250 web page:**